

Title: Petter: Compilerbau (08.06.2015)

Date: Mon Jun 08 14:20:58 CEST 2015

Duration: 94:57 min

Pages: 51

LR(0)-Parser

Attention:

Unfortunately, the *LR(0)*-parser is in general non-deterministic.

We identify two reasons:

Reduce-Reduce-Conflict:

$$[A \rightarrow \gamma \bullet], [A' \rightarrow \gamma' \bullet] \in q \text{ with } A \neq A' \vee \gamma \neq \gamma'$$

Shift-Reduce-Conflict:

$$[A \rightarrow \gamma \bullet], [A' \rightarrow \alpha \bullet a \beta] \in q \text{ with } a \in T$$

for a state $q \in Q$.

Those states are called *LR(0)*-unsuited.

Revisiting the Conflicts of the LR(0)-Automaton

What differentiates the particular Reductions and Shifts?

Input:

* 2 + 40

Pushdown:

($q_0 T$)

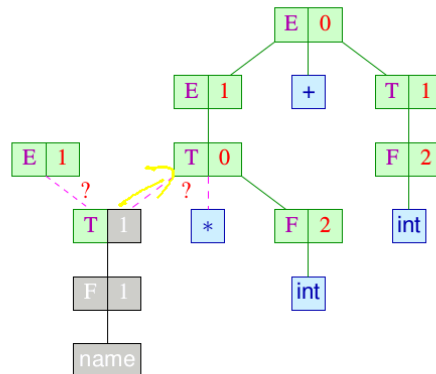

$E \rightarrow E+T \mid T$
 $T \rightarrow T * F \mid F$
 $F \rightarrow (E) \mid \text{int}$

Revisiting the Conflicts of the LR(0)-Automaton

What differentiates the particular Reductions and Shifts?

Input:

+ 40

Pushdown:

($q_0 T$)

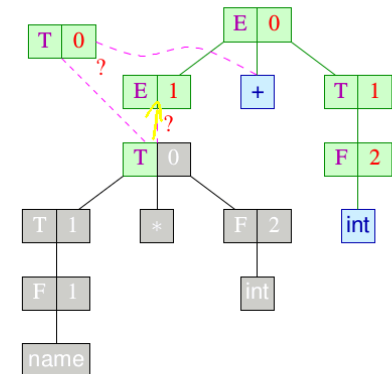

$E \rightarrow E+T \mid T$
 $T \rightarrow T * F \mid F$
 $F \rightarrow (E) \mid \text{int}$

Revisiting the Conflicts of the LR(0)-Automaton

Idea: Matching lookahead with *right context* matters!

Input:

*2 + 40

Pushdown:

(q₀ T)

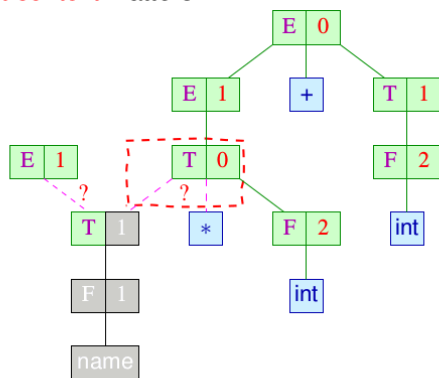

$$\begin{array}{l} E \rightarrow E + T \quad | \quad T \\ T \rightarrow T * F \quad | \quad F \\ F \rightarrow (E) \quad | \quad \text{int} \end{array}$$

128/238

Revisiting the Conflicts of the LR(0)-Automaton

Idea: Matching lookahead with *right context* matters!

Input:

+40

Pushdown:

(q₀ T)

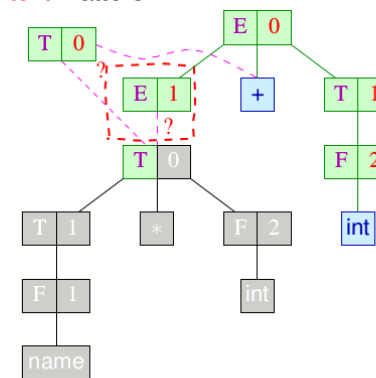

$$\begin{array}{l} E \rightarrow E + T \quad | \quad T \\ T \rightarrow T * F \quad | \quad F \\ F \rightarrow (E) \quad | \quad \text{int} \end{array}$$

128/238

LR(k)-Grammars

Idea: Consider *k*-lookahead in conflict situations.

Definition:

The reduced contextfree grammar *G* is called *LR(k)*-grammar, if for

$\text{First}_k(w) = \text{First}_k(x)$ with:

$$\left. \begin{array}{l} S \xrightarrow{*}_R \alpha A w \rightarrow \alpha \beta w \\ S \xrightarrow{*}_R \alpha' A' w' \rightarrow \alpha \beta w' \end{array} \right\} \text{follows } \alpha = \alpha' \wedge A = A' \wedge w' = x$$

129/238

LR(k)-Grammars

Idea: Consider *k*-lookahead in conflict situations.

Definition:

The reduced contextfree grammar *G* is called *LR(k)*-grammar, if for

$\text{First}_k(w) = \text{First}_k(x)$ with:

$$\left. \begin{array}{l} S \xrightarrow{*}_R \alpha A w \rightarrow \alpha \beta w \\ S \xrightarrow{*}_R \alpha' A' w' \rightarrow \alpha \beta x \end{array} \right\} \text{follows: } \alpha = \alpha' \wedge A = A' \wedge w' = x$$

Strategy for testing Grammars for *LR(k)*-property

- 1 Focus iteratively on all rightmost derivations $S \xrightarrow{*}_R \alpha X w \rightarrow \alpha \beta w$
- 2 Identify handle $\alpha \beta$ in sentence forms $\alpha \beta w$
- 3 Determine minimal *k*, such that $\text{First}_k(w)$ associates β with a unique $X \rightarrow \beta$ for non-prefixfree $\alpha \beta$ s

129/238

LR(k)-Grammars

for example:

$$(1) \quad S \rightarrow A \mid B \quad \boxed{A \rightarrow aAb} \mid 0 \quad B \rightarrow aBbb \mid 1$$

130/238

LR(k)-Grammars

for example:

$$(1) \quad \underline{S \rightarrow A \mid B} \quad A \rightarrow aAb \mid 0 \quad B \rightarrow aBbb \mid 1$$

... is not $LL(k)$ for any k :

Let $S \xrightarrow{*}_R \alpha X w \rightarrow \alpha \beta w$. Then $\alpha \beta$ is of one of these forms:

$$\begin{aligned} &\underline{A}, \underline{B}, \underline{aAb}, \underline{a^n a B b^{2n}} \\ &\quad \quad \quad aaAbbb \\ &\quad \quad \quad aaaaBBBB \\ &\quad \quad \quad a^n \underline{aAb} b^n \\ &\quad \quad \quad a^n \underline{0} b^n \end{aligned}$$

130/238

LR(k)-Grammars

for example:

$$(1) \quad S \rightarrow A \mid B \quad A \rightarrow aAb \mid 0 \quad B \rightarrow aBbb \mid 1$$

... is not $LL(k)$ for any k :

Let $S \xrightarrow{*}_R \alpha X w \rightarrow \alpha \beta w$. Then $\alpha \beta$ is of one of these forms:

$$\underline{A}, \underline{B}, \underline{a^n aAb}, \underline{a^n aBbb}, \underline{a^n 0}, \underline{a^n 1} \quad (n \geq 0)$$

130/238

LR(k)-Grammars

for example:

$$(1) \quad \underline{S \rightarrow A \mid B} \quad A \rightarrow aAb \mid 0 \quad B \rightarrow aBbb \mid 1$$

... is not $LL(k)$ for any k — but $LR(0)$:

Let $S \xrightarrow{*}_R \alpha X w \rightarrow \alpha \beta w$. Then $\alpha \beta$ is of one of these forms:

$$\underline{A}, \underline{B}, \underline{a^n aAb}, \underline{a^n aBbb}, \underline{a^n 0}, \underline{a^n 1} \quad (n \geq 0)$$

130/238

LR(k)-Grammars

for example:

$$(1) \quad S \rightarrow A \mid B \quad A \rightarrow aAb \mid 0 \quad B \rightarrow aBbb \mid 1$$

... is not $LL(k)$ for any k — but $LR(0)$:

Let $S \xrightarrow{*}_R \alpha X w \rightarrow \alpha \beta w$. Then $\alpha \underline{\beta}$ is of one of these forms:

$$\underline{A}, \underline{B}, a^n \underline{aAb}, a^n \underline{aBbb}, a^n \underline{0}, a^n \underline{1} \quad (n \geq 0)$$

$$(2) \quad S \rightarrow aAc \quad \boxed{A \rightarrow Abb} \mid b$$

130/238

LR(k)-Grammars

for example:

$$(1) \quad S \rightarrow A \mid B \quad A \rightarrow aAb \mid 0 \quad B \rightarrow aBbb \mid 1$$

... is not $LL(k)$ for any k — but $LR(0)$:

Let $S \xrightarrow{*}_R \alpha X w \rightarrow \alpha \beta w$. Then $\alpha \underline{\beta}$ is of one of these forms:

$$\underline{A}, \underline{B}, a^n \underline{aAb}, a^n \underline{aBbb}, a^n \underline{0}, a^n \underline{1} \quad (n \geq 0)$$

$$(2) \quad S \rightarrow aAc \quad A \rightarrow Abb \mid b$$

... is also not $LL(k)$ for any k :

Let $S \xrightarrow{*}_R \alpha X w \rightarrow \alpha \beta w$. Then $\alpha \underline{\beta}$ is of one of these forms:

$$a \underline{b}, a \underline{Abb}, a \underline{Ac}$$

130/238

LR(k)-Grammars

for example:

$$(3) \quad S \rightarrow aAc \quad A \rightarrow bbA \mid b$$

131/238

LR(k)-Grammars

for example:

$$(3) \quad S \rightarrow aAc \quad A \rightarrow bbA \mid b$$

Let $S \xrightarrow{*}_R \alpha X w \rightarrow \alpha \beta w$ with $\{y\} = \text{First}_k(w)$ then $\alpha \underline{\beta} y$ is of one of these forms:

$$a b^{2n} \underline{bc}, a b^{2n} \underline{bbAc}, a \underline{Ac}$$

131/238

LR(k)-Grammars

for example:

(3) $S \rightarrow aAc \quad A \rightarrow bbA \mid b$... is not $LR(0)$, but $LR(1)$:

Let $S \xrightarrow{*}_R \alpha X w \rightarrow \alpha \beta w$ with $\{y\} = \text{First}_k(w)$ then $\alpha \underline{\beta} y$ is of one of these forms:

$$ab^{2n} \underline{b}c, ab^{2n} \underline{bb}Ac, \underline{a}Ac$$

131/238

LR(k)-Grammars

for example:

(3) $S \rightarrow aAc \quad A \rightarrow bbA \mid b$

Let $S \xrightarrow{*}_R \alpha X w \rightarrow \alpha \beta w$ with $\{y\} = \text{First}_k(w)$ then $\alpha \underline{\beta} y$ is of one of these forms:

$$ab^{2n} \underline{b}c, ab^{2n} \underline{bb}Ac, \underline{a}Ac$$

131/238

LR(k)-Grammars

for example:

(3) $S \rightarrow aAc \quad A \rightarrow bbA \mid b$... is not $LR(0)$, but $LR(1)$:

Let $S \xrightarrow{*}_R \alpha X w \rightarrow \alpha \beta w$ with $\{y\} = \text{First}_k(w)$ then $\alpha \underline{\beta} y$ is of one of these forms:

$$ab^{2n} \underline{b}c, ab^{2n} \underline{bb}Ac, \underline{a}Ac$$

(4) $S \rightarrow aAc \quad A \rightarrow bAb \mid b$

131/238

LR(k)-Grammars

for example:

(3) $S \rightarrow aAc \quad A \rightarrow bbA \mid b$... is not $LR(0)$, but $LR(1)$:

Let $S \xrightarrow{*}_R \alpha X w \rightarrow \alpha \beta w$ with $\{y\} = \text{First}_k(w)$ then $\alpha \underline{\beta} y$ is of one of these forms:

$$ab^{2n} \underline{b}c, ab^{2n} \underline{bb}Ac, \underline{a}Ac$$

(4) $S \rightarrow aAc \quad A \rightarrow bAb \mid b$

Consider the rightmost derivations:

$$S \xrightarrow{*}_R ab^n Ab^n c \rightarrow ab^n \underline{bb}^n c$$

131/238

LR(k)-Grammars

for example:

(3) $S \rightarrow aAc \quad A \rightarrow bbA \mid b \quad \dots$ is not $LR(0)$, but $LR(1)$:

Let $S \xrightarrow*_R \alpha Xw \rightarrow \alpha\beta w$ with $\{y\} = \text{First}_k(w)$ then $\alpha\beta y$ is of one of these forms:

$$ab^{2n}bc, ab^{2n}bbAc, aAc$$

(4) $S \rightarrow aAc \quad A \rightarrow bAb \mid b \quad \dots$ is not $LR(k)$ for any $k \geq 0$:

Consider the rightmost derivations:

$$S \xrightarrow*_R ab^n Ab^n c \rightarrow ab^n bb^n c$$

131/238

Revisiting the Conflicts of the LR(0)-Automaton

Idea: Matching lookahead with *right context* matters!

Input:

*2 + 40

Pushdown:

(q_0 T)

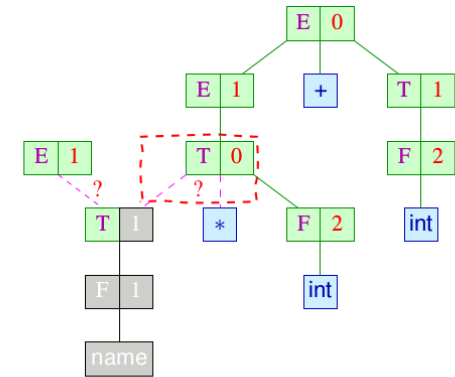

$$\begin{array}{l} E \rightarrow E+T \quad | \quad T \\ T \rightarrow T*F \quad | \quad F \\ F \rightarrow (E) \quad | \quad \text{int} \end{array}$$

128/238

LR(1)-Parsing

Idea: Let's equip items with 1-lookahead

Definition LR(1)-Item

An $LR(1)$ -item is a pair $[B \rightarrow \alpha \bullet \beta, x]$ with

$$x \in \text{Follow}_1(B) = \bigcup \{ \text{First}_1(\nu) \mid S \xrightarrow{*} \mu B \nu \}$$

132/238

Admissible LR(1)-Items

The item $[B \rightarrow \alpha \bullet \beta, x]$ is *admissible* for $\gamma \alpha$ if:

$$S \xrightarrow*_R \gamma B w \quad \text{with} \quad \{x\} = \text{First}_1(w)$$

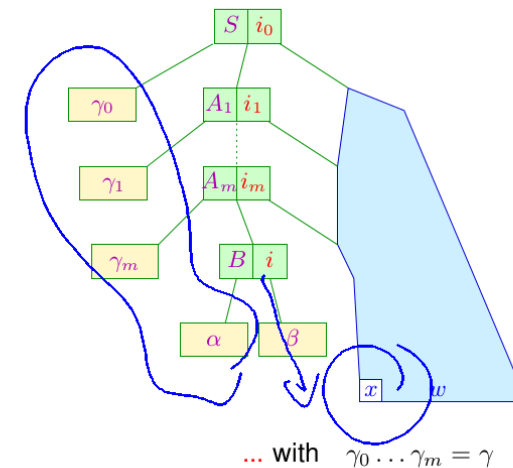

... with $\gamma_0 \dots \gamma_m = \gamma$

133/238

The Characteristic LR(1)-Automaton

The set of admissible $LR(1)$ -items for viable prefixes is again computed with the help of the finite automaton $c(G, 1)$.

The automaton $c(G, 1)$:

States: $LR(1)$ -items

Start state: $[S' \rightarrow \bullet S, \epsilon]$

Final states: $\{[B \rightarrow \gamma \bullet, x] \mid B \rightarrow \gamma \in P, x \in \text{Follow}_1(B)\}$

Transitions:

- (1) $([A \rightarrow \alpha \bullet X \beta, x], X, [A \rightarrow \alpha X \bullet \beta, x]), X \in (N \cup T)$
- (2) $([A \rightarrow \alpha \bullet B \beta, x], \epsilon, [A \rightarrow \alpha B \bullet, x]),$
 $A \rightarrow \alpha B \beta, B \rightarrow \gamma \in P, x' \in \text{First}_1(\beta) \odot \{x\};$

134/238

The Canonical LR(1)-Automaton

The canonical $LR(1)$ -automaton $LR(G, 1)$ is created from $c(G, 1)$, by performing arbitrarily many ϵ -transitions and then making the resulting automaton **deterministic ...**

135/238

The Canonical LR(1)-Automaton

The canonical $LR(1)$ -automaton $LR(G, 1)$ is created from $c(G, 1)$, by performing arbitrarily many ϵ -transitions and then making the resulting automaton **deterministic ...**

But again, it can be constructed **directly** from the grammar; analogously to $LR(0)$, we need the ϵ -closure δ_ϵ^* as a helper function:

$$\delta_\epsilon^*(q) = q \cup \{ [C \rightarrow \bullet \gamma, x] \mid \exists [A \rightarrow \alpha \bullet B \beta', x'] \in q, \beta \in (N \cup T)^* : B \rightarrow^* C \beta \wedge x \in \text{First}_1(\beta \beta') \odot \{x'\} \}$$

135/238

The Characteristic LR(1)-Automaton

The set of admissible $LR(1)$ -items for viable prefixes is again computed with the help of the finite automaton $c(G, 1)$.

The automaton $c(G, 1)$:

States: $LR(1)$ -items

Start state: $[S' \rightarrow \bullet S, \epsilon]$

Final states: $\{[B \rightarrow \gamma \bullet, x] \mid B \rightarrow \gamma \in P, x \in \text{Follow}_1(B)\}$

Transitions:

- (1) $([A \rightarrow \alpha \bullet X \beta, x], X, [A \rightarrow \alpha X \bullet \beta, x]), X \in (N \cup T)$
- (2) $([A \rightarrow \alpha \bullet B \beta, x], \epsilon, [A \rightarrow \alpha B \bullet, x]),$
 $A \rightarrow \alpha B \beta, B \rightarrow \gamma \in P, x' \in \text{First}_1(\beta) \odot \{x\};$

This automaton works like $c(G)$ — but additionally manages a 1-prefix from Follow_1 of the left-hand sides.

134/238

The Canonical LR(1)-Automaton

The canonical LR(1)-automaton $LR(G, 1)$ is created from $c(G, 1)$, by performing arbitrarily many ϵ -transitions and then making the resulting automaton **deterministic** ...

But again, it can be constructed **directly** from the grammar; analogously to LR(0), we need the ϵ -closure δ_ϵ^* as a helper function:

$$\delta_\epsilon^*(q) = q \cup \{ [C \rightarrow \bullet \gamma, x] \mid \exists [A \rightarrow \alpha \bullet B \beta', x'] \in q, \beta \in (N \cup T)^* : B \rightarrow^* C \beta \wedge x \in \text{First}_1(\beta \beta') \odot \{x'\} \}$$

Then, we define:

States: Sets of LR(1)-items;

Start state: $\delta_\epsilon^* \{ [S' \rightarrow \bullet S, \epsilon] \}$

Final states: $\{ q \mid \exists A \rightarrow \alpha \in P : [A \rightarrow \alpha \bullet, x] \in q \}$

Transitions: $\delta(q, X) = \delta_\epsilon^* \{ [A \rightarrow \alpha X \bullet \beta, x] \mid [A \rightarrow \alpha \bullet X \beta, x] \in q \}$

135/238

The Canonical LR(1)-Automaton

For example:

$$\begin{array}{l} E \rightarrow E + T \mid T \\ T \rightarrow T * F \mid F \\ F \rightarrow (E) \mid \text{int} \end{array}$$

$$\text{First}_1(S') = \text{First}_1(E) = \text{First}_1(T) = \text{First}_1(F) = \text{name, int, (}$$

$$\begin{array}{l} q_0 = \{ [S' \rightarrow \bullet E, \epsilon], [E \rightarrow \bullet E + T, \epsilon, +], [E \rightarrow \bullet T, \epsilon, +], [T \rightarrow \bullet T * F, \epsilon, +, *], [T \rightarrow \bullet F, \epsilon, +, *], [F \rightarrow \bullet (E), \epsilon, +, *], [F \rightarrow \bullet \text{int}, \epsilon, +, *] \} \\ q_1 = \delta(q_0, E) = \{ [S' \rightarrow E \bullet, \epsilon], [E \rightarrow E \bullet + T, \epsilon, +] \} \\ q_2 = \delta(q_0, T) = \{ [E \rightarrow T \bullet, \epsilon, +], [T \rightarrow T \bullet * F, \epsilon, +, *] \} \\ q_3 = \delta(q_0, F) = \{ [T \rightarrow F \bullet, \epsilon, +, *] \} \\ q_4 = \delta(q_0, \text{int}) = \{ [F \rightarrow \text{int} \bullet, \epsilon, +, *] \} \\ q_5 = \delta(q_0, () = \{ [F \rightarrow (\bullet E), \epsilon, +, *], [E \rightarrow \bullet E + T, \epsilon, +], [E \rightarrow \bullet T, \epsilon, +], [T \rightarrow \bullet T * F, \epsilon, +, *], [T \rightarrow \bullet F, \epsilon, +, *], [F \rightarrow (\bullet (E), \epsilon, +, *], [F \rightarrow (\bullet \text{int}, \epsilon, +, *] \} \end{array}$$

136/238

The Canonical LR(1)-Automaton

For example:

$$\begin{array}{l} E \rightarrow E + T \mid T \\ T \rightarrow T * F \mid F \\ F \rightarrow (E) \mid \text{int} \end{array}$$

$$\text{First}_1(S') = \text{First}_1(E) = \text{First}_1(T) = \text{First}_1(F) = \text{name, int, (}$$

$$\begin{array}{l} q_0 = \{ [S' \rightarrow \bullet E, \{\epsilon\}], [E \rightarrow \bullet E + T, \{\epsilon, +\}], [E \rightarrow \bullet T, \{\epsilon, +\}], [T \rightarrow \bullet T * F, \{\epsilon, +, *\}], [T \rightarrow \bullet F, \{\epsilon, +, *\}], [F \rightarrow \bullet (E), \{\epsilon, +, *\}], [F \rightarrow \bullet \text{int}, \{\epsilon, +, *\}] \} \\ q_1 = \delta(q_0, E) = \{ [S' \rightarrow E \bullet, \epsilon], [E \rightarrow E \bullet + T, \epsilon, +] \} \\ q_2 = \delta(q_0, T) = \{ [E \rightarrow T \bullet, \epsilon, +], [T \rightarrow T \bullet * F, \epsilon, +, *] \} \\ q_3 = \delta(q_0, F) = \{ [T \rightarrow F \bullet, \epsilon, +, *] \} \\ q_4 = \delta(q_0, \text{int}) = \{ [F \rightarrow \text{int} \bullet, \epsilon, +, *] \} \\ q_5 = \delta(q_0, () = \{ [F \rightarrow (\bullet E), \epsilon, +, *], [E \rightarrow \bullet E + T, \epsilon, +], [E \rightarrow \bullet T, \epsilon, +], [T \rightarrow \bullet T * F, \epsilon, +, *], [T \rightarrow \bullet F, \epsilon, +, *], [F \rightarrow (\bullet (E), \epsilon, +, *], [F \rightarrow (\bullet \text{int}, \epsilon, +, *] \} \end{array}$$

136/238

The screenshot shows a PDF viewer window titled 'cb.pdf' with a search bar and zoom level of 383.05%. The content of the slide is visible, including the grammar rules and the transition table. A green box highlights the state $q_1 = \delta(q_0, E)$. There are blue arrows pointing to the state definition for q_0 and some scribbles over parts of the transition table.

cb.pdf

File Edit View Go Bookmarks Help

136 (309 of 511) 383.05%

$First_1(S') = First_1(E) = First_1(T) = First_1(F)$

$q_0 = \{ [S' \rightarrow \bullet E, \{\epsilon\}], [E \rightarrow \bullet E + T, \{\epsilon, +\}], [E \rightarrow \bullet T, \{\epsilon, +\}], [T \rightarrow \bullet T * F, \{\epsilon, +, *\}], [T \rightarrow \bullet F, \{\epsilon, +, *\}], [F \rightarrow \bullet (E), \{\epsilon, +, *\}], [F \rightarrow \bullet int, \{\epsilon, +, *\}] \}$
 $q_1 = \delta(q_0, E) = \{ [S' \rightarrow E \bullet, \{\epsilon\}], [E \rightarrow E \bullet + T, \{\epsilon, +\}] \}$
 $q_2 = \delta(q_0, T) = \{ [E \rightarrow T \bullet, \{\epsilon, +\}], [T \rightarrow T \bullet * F, \{\epsilon, +, *\}] \}$

cb.pdf

File Edit View Go Bookmarks Help

136 (309 of 511) 383.05%

$st_1(E) = First_1(T) = First_1(F) = name, int, ($

$q_3 = \delta(q_0, F) = \{ [T \rightarrow F \bullet, \{\epsilon, +, *\}] \}$
 $q_4 = \delta(q_0, int) = \{ [F \rightarrow int \bullet, \{\epsilon, +, *\}] \}$
 $q_5 = \delta(q_0, () = \{ [F \rightarrow (\bullet E), \{\epsilon, +, *\}], [E \rightarrow \bullet E + T, \{\epsilon, +\}], [E \rightarrow \bullet T, \{\epsilon, +\}], [T \rightarrow \bullet T * F, \{\epsilon, +, *\}], [T \rightarrow \bullet F, \{\epsilon, +, *\}], [F \rightarrow \bullet (E), \{\epsilon, +, *\}], [F \rightarrow \bullet int, \{\epsilon, +, *\}] \}$

cb.pdf

File Edit View Go Bookmarks Help

136 (309 of 511) 383.05%

$q_3 = \delta(q_0, F) = \{ [T \rightarrow F \bullet, \{\epsilon, +, *\}] \}$
 $q_4 = \delta(q_0, int) = \{ [F \rightarrow int \bullet, \{\epsilon, +, *\}] \}$
 $q_5 = \delta(q_0, () = \{ [F \rightarrow (\bullet E), \{\epsilon, +, *\}], [E \rightarrow \bullet E + T, \{\epsilon, +\}], [E \rightarrow \bullet T, \{\epsilon, +\}], [T \rightarrow \bullet T * F, \{\epsilon, +, *\}], [T \rightarrow \bullet F, \{\epsilon, +, *\}], [F \rightarrow \bullet (E), \{\epsilon, +, *\}], [F \rightarrow \bullet int, \{\epsilon, +, *\}] \}$

136 / 238

The Canonical LR(1)-Automaton

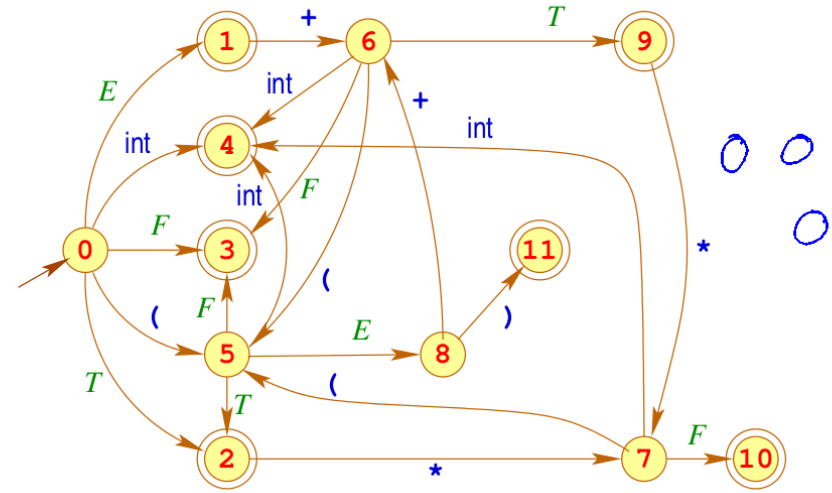

The Canonical LR(1)-Automaton

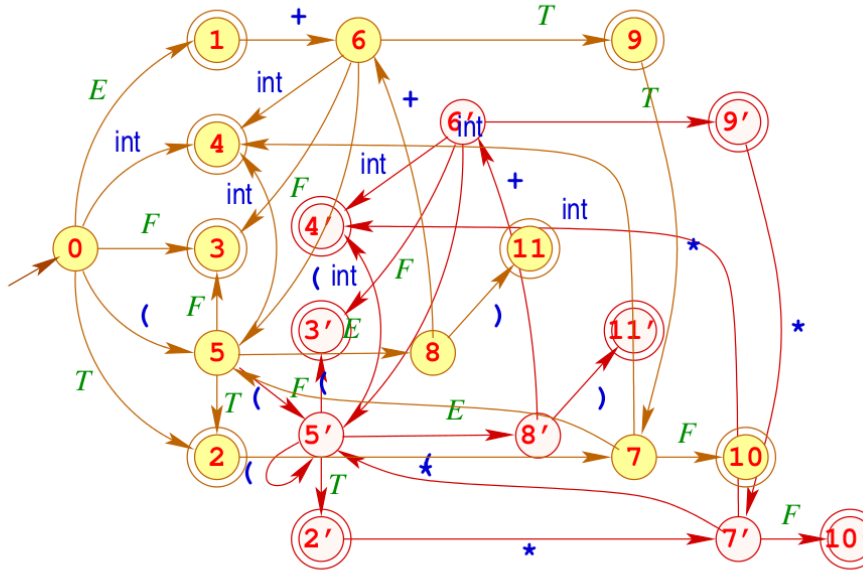

139/238

The Canonical LR(1)-Automaton

Discussion:

- In the example, the number of states was almost doubled ... and it can become even worse
- The conflicts in states q_1, q_2, q_9 are now resolved !
e.g. we have for:

$$q_9 = \left\{ \left[E \rightarrow E + T \bullet, \{ \epsilon, + \} \right], \left[T \rightarrow T \bullet * F, \{ \epsilon, +, * \} \right] \right\}$$

with:

$$\{ \epsilon, + \} \cap (\text{First}_1(*F) \odot \{ \epsilon, +, * \}) = \{ \epsilon, + \} \cap \{ * \} = \emptyset$$

140/238

The LR(1)-Parser:

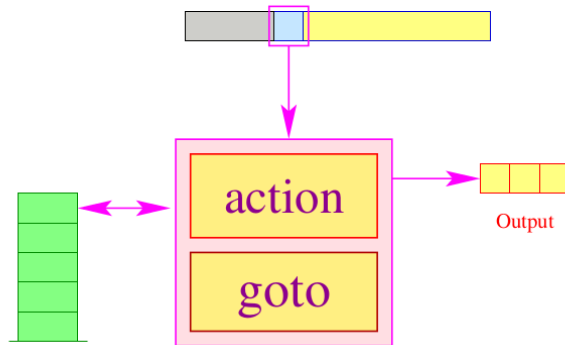

- The **goto**-table encodes the transitions:
 $\text{goto}[q, X] = \delta(q, X) \in Q$
- The **action**-table describes for every state q and possible lookahead w the necessary action.

141/238

The LR(1)-Parser:

Possible actions are:

shift // Shift-operation
reduce ($A \rightarrow \gamma$) // Reduction with callback/output
error // Error

... for example:

$E \rightarrow E + T^0 \mid T^1$
 $T \rightarrow T * F^0 \mid F^1$
 $F \rightarrow (E)^0 \mid \text{int}^1$

action	ϵ	int	()	+	*
q_1	$S', 0$					s
q_2	$E, 1$					s
q'_2			$E, 1$			s
q_3	$T, 1$			$T, 1$	$T, 1$	$T, 1$
q'_3			$T, 1$	$T, 1$	$T, 1$	$T, 1$
q_4	$F, 1$			$F, 1$	$F, 1$	$F, 1$
q'_4			$F, 1$	$F, 1$	$F, 1$	$F, 1$
q_9	$E, 0$			$E, 0$		s
q'_9			$E, 0$	$E, 0$		s
q_{10}	$T, 0$			$T, 0$	$T, 0$	$T, 0$
q'_{10}			$T, 0$	$T, 0$	$T, 0$	$T, 0$
q_{11}	$F, 0$			$F, 0$	$F, 0$	$F, 0$
q'_{11}			$F, 0$	$F, 0$	$F, 0$	$F, 0$

143/238

The LR(1)-Parser

The construction of the LR(1)-parser:

States: $Q \cup \{f\}$ (f fresh)

Start state: q_0

Final state: f

Transitions:

Shift: (p, a, pq) if $q = \text{goto}[q, a]$,
 $s = \text{action}[p, w]$

Reduce: $(pq_1 \dots q_{|\beta|}, \epsilon, pq)$ if $[A \rightarrow \beta \bullet] \in q_{|\beta|}$,
 $q = \text{goto}(p, A)$,
 $[A \rightarrow \beta \bullet] = \text{action}[q_{|\beta|}, w]$

Finish: $(q_0 p, \epsilon, f)$ if $[S' \rightarrow S \bullet] \in p$

with $LR(G, 1) = (Q, T, \delta, q_0, F)$.

142/238

The Canonical LR(1)-Automaton

In general:

We identify two conflicts:

Reduce-Reduce-Conflict:

$[A \rightarrow \gamma \bullet, x], [A' \rightarrow \gamma' \bullet, x] \in q$ with $A \neq A' \vee \gamma \neq \gamma'$

Shift-Reduce-Conflict:

$[A \rightarrow \gamma \bullet, x], [A' \rightarrow \alpha \bullet a \beta, y] \in q$
 with $a \in T$ und $x \in \{a\}$.

for a state $q \in Q$.

Such states are now called **LR(1)-unsuited**

144/238

The Canonical LR(1)-Automaton

In general:

We identify two conflicts:

Reduce-Reduce-Conflict:

$[A \rightarrow \gamma \bullet, x], [A' \rightarrow \gamma' \bullet, x] \in q$ with $A \neq A' \vee \gamma \neq \gamma'$

Shift-Reduce-Conflict:

$[A \rightarrow \gamma \bullet, x], [A' \rightarrow \alpha \bullet a \beta, y] \in q$
 with $a \in T$ und $x \in \{a\} \circ_k \text{First}_k(\beta) \circ_k \{y\}$.

for a state $q \in Q$.

Such states are now called **LR(k)-unsuited**

144/238

Special LR(k)-Subclasses

Theorem:

A reduced contextfree grammar G is called **LR(k)** iff the canonical **LR(k)**-automaton $LR(G, k)$ has no **LR(k)-unsuited** states.

145/238

Special LR(k)-Subclasses

Theorem:

A reduced contextfree grammar G is called $LR(k)$ iff the canonical $LR(k)$ -automaton $LR(G, k)$ has no $LR(k)$ -unsuited states.

Discussion:

- Our example apparently is $LR(1)$
- In general, the canonical $LR(k)$ -automaton has much more states than $LR(G) = LR(G, 0)$
- Therefore in practice, subclasses of $LR(k)$ -grammars are often considered, which only use $LR(G) \dots$

145 / 238

Special LR(k)-Subclasses

Theorem:

A reduced contextfree grammar G is called $LR(k)$ iff the canonical $LR(k)$ -automaton $LR(G, k)$ has no $LR(k)$ -unsuited states.

Discussion:

- Our example apparently is $LR(1)$
- In general, the canonical $LR(k)$ -automaton has much more states than $LR(G) = LR(G, 0)$
- Therefore in practice, subclasses of $LR(k)$ -grammars are often considered, which only use $LR(G) \dots$
- For resolving conflicts, the items are assigned special lookahead-sets:
 - ① independently on the state itself \implies Simple $LR(k)$
 - ② dependent on the state itself \implies $LALR(k)$

145 / 238

Parsing Methods

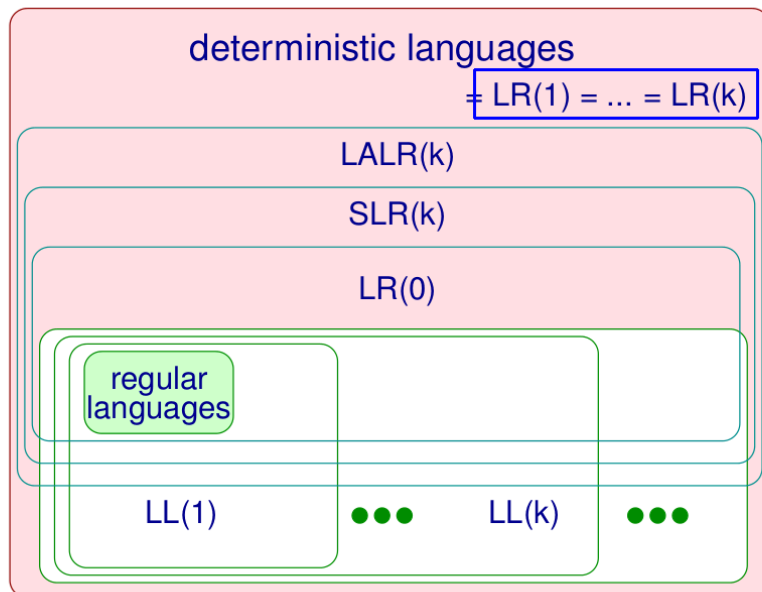

147 / 238

Lexical and Syntactical Analysis:

Concept of specification and implementation:

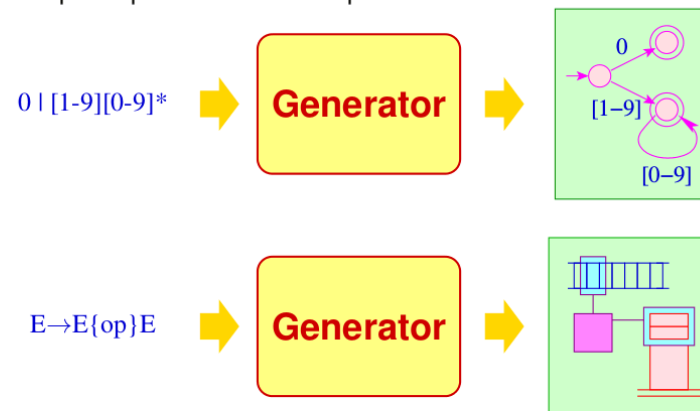

149 / 238

Lexical and Syntactical Analysis:

From Regular Expressions to Finite Automata

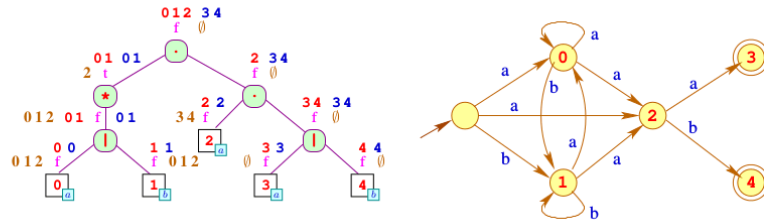

From Finite Automata to Scanners

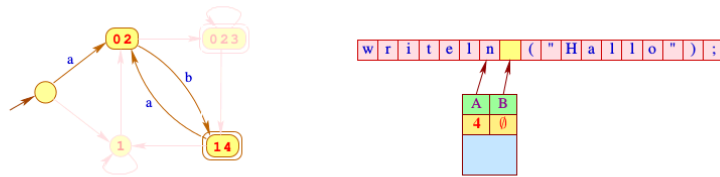

150/238

Lexical and Syntactical Analysis:

Computation of lookahead sets:

$$\begin{aligned}
 F_e(S') &\supseteq F_e(E) & F_e(E) &\supseteq F_e(E) \\
 F_e(E) &\supseteq F_e(T) & F_e(T) &\supseteq F_e(T) \\
 F_e(T) &\supseteq F_e(F) & F_e(F) &\supseteq \{ (, int, name) \}
 \end{aligned}$$

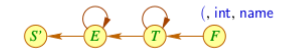
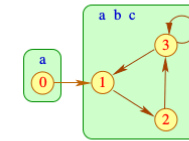

From Item-Pushdown Automata to LL(1)-Parsers:

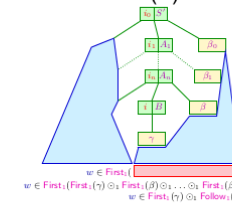
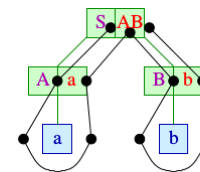

$w \in \text{First}_1(\alpha)$
 $w \in \text{First}_1(\text{First}_1(\gamma) \cup \text{First}_1(\beta) \cup \dots \cup \text{First}_1(\alpha_i))$
 $w \in \text{First}_1(\gamma) \cup \text{Follow}_1(\beta)$

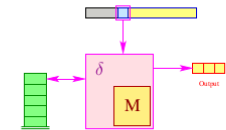

151/238

Lexical and Syntactical Analysis:

From characteristic to canonical Automata:

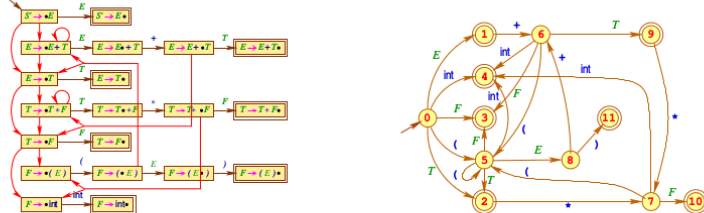

From Shift-Reduce-Parsers to LR(1)-Parsers:

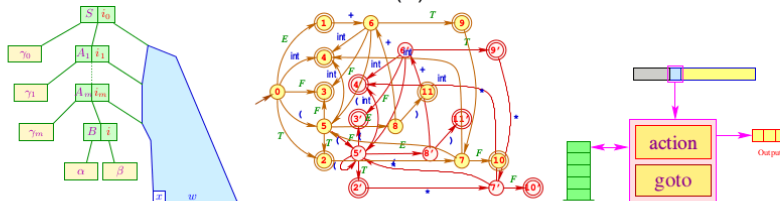

152/238

Topic:
Semantic Analysis

153/238